

STANDARD OPERATING PROCEDURES



SLEET SCRAPERS

During periods of freezing rain, sleet or heavy snow, ice can accumulate on the third rail, causing serious problems for rail service operations. The ice accumulation prevents the shoes from making proper contact with the third rail, causing heavy arcing between rail and shoes and also causing a loss of power. Under extreme icing conditions this loss of power can be so serious that a train may be totally unable to move.

**cta**

SLEET SCRAPING DEVICES

To remove ice from the third rail, cars are equipped with sleet scraping devices. These devices are located on the block and have sharp metal blades which can be lowered to contact the third rail and scrape off the ice as the train is operated over the route.

On all cars the sleet devices are charged with 600 volts through a copper shunt attached to the shoe fuse bolt. When lowered these sleet devices also serve as additional current collecting devices.

SERIES 6000 (SLIPPER TYPE SHOE) (Sleet scraper is shown in lowered position)

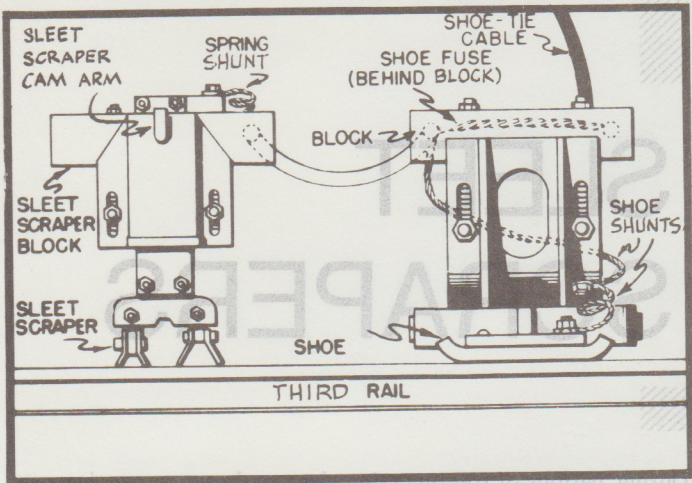

SERIES 6000 (GRAVITY TYPE SHOE), SERIES 2000 AND SERIES 2400 (Sleet scraper is shown in lowered position)

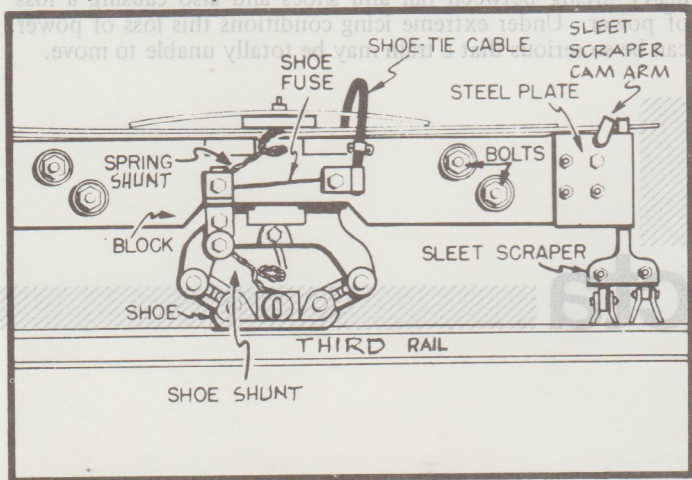

SERIES 2200

(Sleet scraper is shown in raised position)

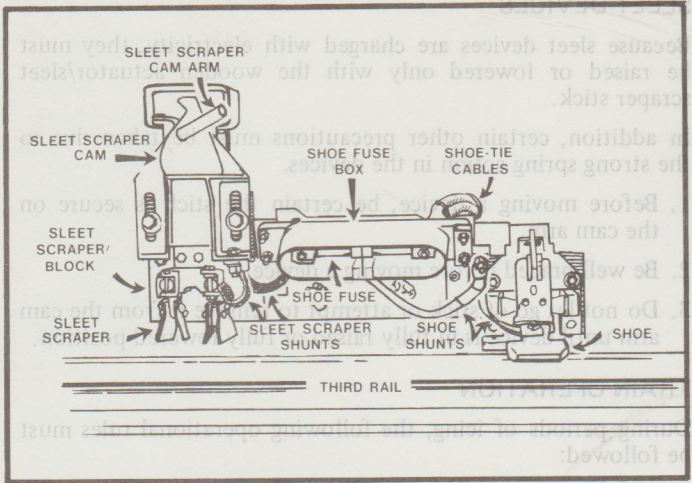

LOWERING SLEET DEVICES

When ice begins to accumulate to the extent that heavy arcing and power losses are occurring, all devices on all cars of a train must be lowered. Lowering all devices provides a more complete removal of ice and provides the maximum amount of additional current collecting surface. This helps to reduce arcing and thereby reduces the danger of having a block become grounded.

To lower sleet devices, take the following steps:

1. Obtain an actuator/sleet scraper stick from the motor cab.
2. Fit the tube end of the stick securely over the cam arm.
3. Raise the stick until the sleet device reaches the fully lowered position.

RAISING SLEET DEVICES

All sleet devices must be raised when they are no longer needed or when a train is laid up.

To raise a sleet device, take the following steps:

1. Obtain an actuator/sleet scraper stick from the motor cab.
2. Fit the tube end of the stick securely over the cam arm.
3. Lower the stick until the sleet device reaches the fully raised position.

SAFETY PRECAUTIONS WHEN RAISING OR LOWERING SLEET DEVICES

Because sleet devices are charged with electricity, they must be raised or lowered only with the wooden actuator/sleet scraper stick.

In addition, certain other precautions must be taken due to the strong spring action in the devices.

1. Before moving a device, be certain the stick is secure on the cam arm.
2. Be well braced before moving a device.
3. Do not let go of stick or attempt to remove it from the cam arm until device is in fully raised or fully lowered position.

TRAIN OPERATION

During periods of icing, the following operational rules must be followed:

1. Motormen must not move the cineston (controller) handle between power and coast positions when arcing occurs. This action actually causes more arcing. Keep the handle in a power position at all times except when it is necessary to reduce speed or to make a stop.
2. Accelerate slowly after each stop. Attempts to accelerate at too high a rate cause heavy arcing and may result in loss of power on a section. The following procedures for accelerating various car series should be used.

Series 2000, 2200 and 2400 - Start with cineston (controller) handle in 2nd pt. of power. If car reaches 20 MPH, move handle to 4th pt. of power.

Series 6000 - Start with and run with cineston handle in 1st pt. of power at all times.