

CLEARING A GROUND AT A TROLLEY BLOCK

Before attempting to clear a ground at a trolley block, determine whether power is "off" or "on."

IF POWER IS OFF, contact the Radio Dispatcher and have power held off. Then follow the TROUBLE SHOOTING PROCEDURES inside folder.

IF POWER IS ON, what you do is determined by where you are

1. If operating where there is trolley wire only
 - a. Pull down the trolley pole of the car or unit with the grounded block
 - b. Follow TROUBLE SHOOTING PROCEDURES inside folder.

2. If operating where there is trolley rail only or both trolley rail and trolley wire

- a. Attempt to move the train so that the grounded block is on a dead spot (If the grounded block cannot be moved to a dead spot, have the power taken off the section)

- b. Insulate the car which has the grounded block

- (1) Pull down the trolley pole on that car or unit, if it is up

- (2) Place a slipper under any trolley shoe which is still contacting trolley rail

- (3) Raise any sleet device which is still contacting trolley rail

- c. If power is off, have it restored (If unable to insulate car, leave power off)

- d. Follow TROUBLE SHOOTING PROCEDURES inside folder.

TROUBLE SHOOTING PROCEDURES

Determine which of the following troubles exists and take the action indicated to correct that trouble.

GROUNDING SHOE TIE CABLE (usually indicated by broken insulation on the cable or burn marks at the cable)

- * 1. Cut or break all four shoe fuses on the car with the ground (use long-handled sleet scraper)
2. Cut 7-point switch on all-electric cars
3. Remove slippers if they were used
4. If power is off, have it restored
5. Proceed (on single cars, and on units with only one car collecting current, have follower couple)

GROUNDING SLEET DEVICE (usually indicated by burn marks or carbonization between the steel plate and one of the bolts on the trolley block)

1. Attempt to raise the grounded sleet device
 - a. If able to raise device, cut or break the spring pig-tail (use long-handled sleet scraper)
 - b. If unable to raise device
 - (1) Have power taken off
 - (2) Force device free and secure it
 - (3) Cut or break the spring pig-tail (use long-handled sleet scraper)
2. Remove slippers if they were used
3. If power is off, have it restored
4. Proceed

GROUNDING TROLLEY SHOE (usually caused by a broken shoe-link which allows the shoe to drop and contact a ground)

- * 1. Tie up defective trolley shoe
2. Cut or break the shoe fuse (use long-handled sleet scraper)
3. Remove slippers if they were used
4. If power is off, have it restored
5. Proceed

NOTE: If a shoe pig-tail breaks and becomes grounded, it will usually burn itself off. If it does not burn off, cut it. (Use long-handled sleet scraper)

*See back page for the use of Trolley Shoe hooks.

DIAGRAMS OF TROLLEY BLOCKS

CARS 6201 - 6510

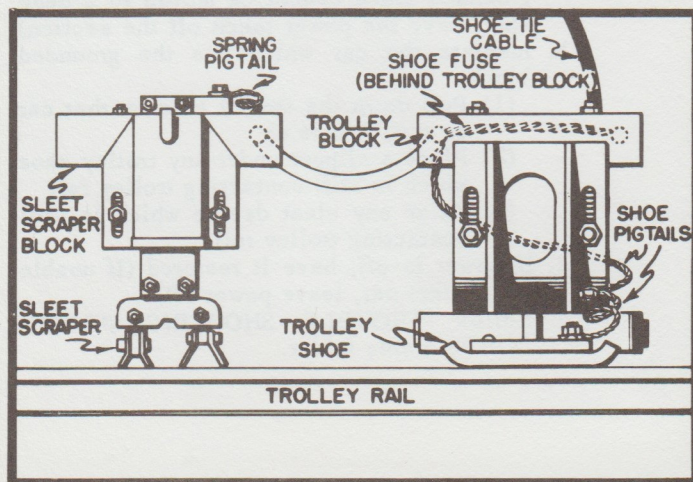

ALL CARS EXCEPT 6201 - 6510

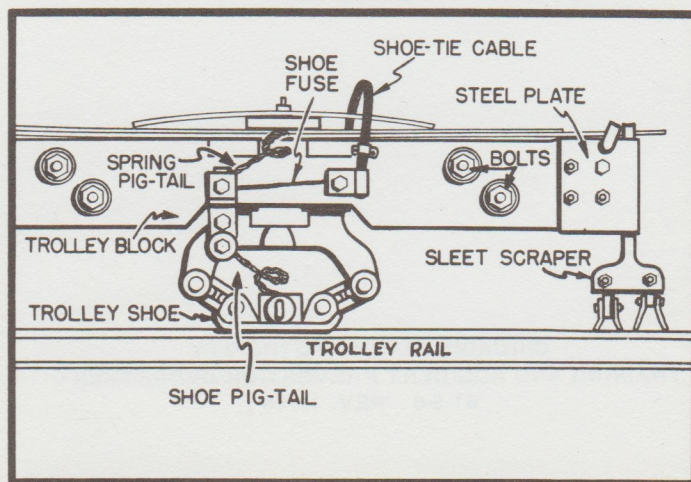

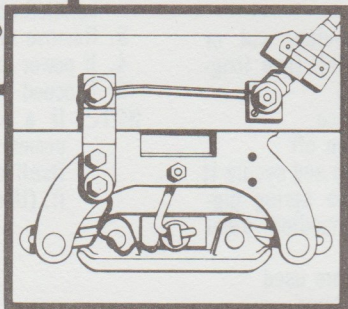
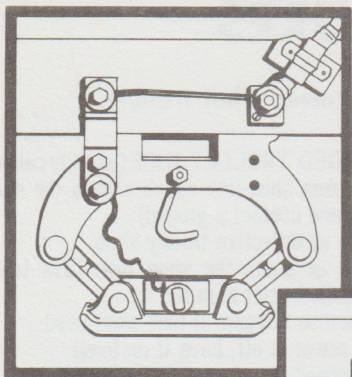

Hooks are being installed to eliminate the need for cutting fuses or tying up shoes. To insulate cars so equipped, simply lift the shoe and insert the hook in the eyebolt.